



Olympia

1375.40LG/OiG

DESIGN

Rotisol's traditional rustic-style rotisserie, the Olympia, is an attractive show-piece for any restaurant or kitchen and is used by chefs in Michelin's star restaurants around the world.

The visible flames from Rotisol's patented burners spread up the porcelain wicks creating a spectacular visual that can be seen through the front and side glass doors.

Spits are driven by an elegant system of chains and pulleys, rotating at 2 ½ times per minute, ensuring perfectly cooked, self-basting poultry, meat, vegetables and fish.

The optional Vertical Spit System with its choice of eight hanging accessories expands the menu possibilities even more and adds additional visual appeal.

FEATURES

- Rotisol patented burners
- Tempered K-glass front and side doors
- Decorative roof included
- Pre-installed vertical spit system
- Independent motor for each spit
- Equipped with bottom drip tray with built-in drainage
- Powerful halogen lamps
- Delivered with 4 prongless spits (CUI13)
- Base on casters with brakes





1375.40LG
Black enamel and brass



TECHNICAL DETAILS

Overview of some of the standard features.

	Cast iron with ceramic wicks provides a magnificent display of flames		Visible rustic pulleys and drive chains for added front-of-house appeal		Pre-installed vertical spit system allows for vertical cooking
	Decorative terracotta firebricks absorb and radiate the heat		Gas knobs in brass or chrome finish allow fine tuning of the gas flow		Middle drip pan allows separation of products to prevent cross-contamination

ACCESSORIES

A wide variety of accessories are available. Please consult us. See video of available [accessories](#) and of [vertical spit system](#) online.

CUI13 Anti-cutting prongless V-spit.		BP13 Chicken spit.		BRC13 Rectangular basket spit.	
BS13 Spit for ham / turkey.		BRRO13 Roast-clamp spit.		BA13 Lamb/suckling-pig spit.	
BCR13 Spatchcock chicken basket.		DEC Spit mover.		PID13 Tray for unspitting.	

Front view

Rotisserie with roof (optional)
and base on casters (optional)

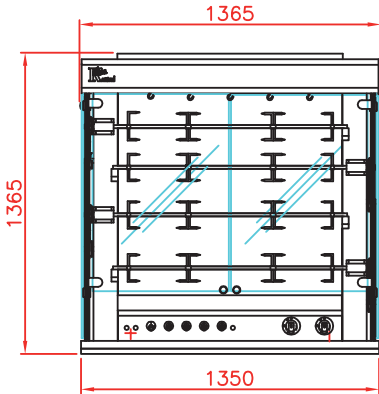

Side view

Rotisserie with roof (optional)
and base on casters (optional)

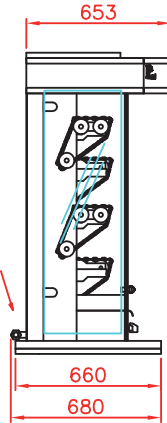

Top view

Rotisserie with roof (optional)
and base on casters (optional)

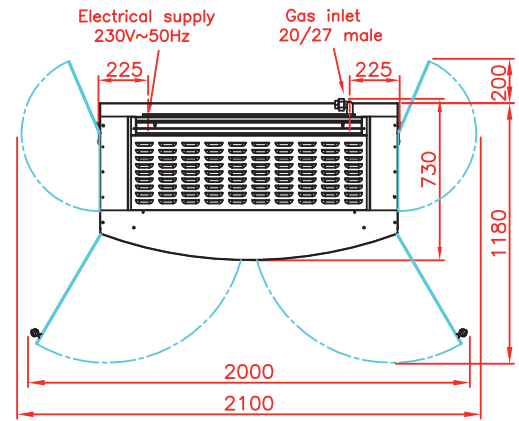

GRANDES FLAMMES
OLYMPIA

Electrical and Gas
Connection, in rear

Heated base cabinet
with drawers
(2,055kW)
(Optional)

Base or Heated base cabinet
with doors
(2,055kW)
(Optional)

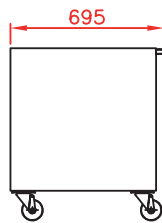
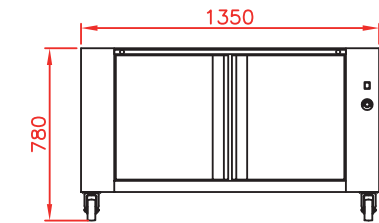
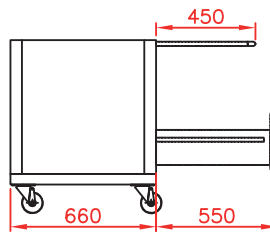
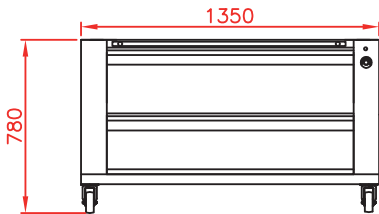

1375.40LG
Black enamel and chrome



Revised :
October 2018

SPECIFICATIONS

Capacity	20/24 poultries
Gas power	30 kW
Power supply	208-230V-50Hz/60Hz
Electrical power	0.62 kW
Weight and size (HxDxW)	320 kg ; 2145 x 730 x 1365 mm
Shipping weight and size	371 kg ; 2220 x 760 x 1500 mm
Guarantee	1 year parts



DISTRIBUTOR / AGENT

Rotisol S.A.S.

Zone industrielle La Trentaine, Avenue Gustave Eiffel

77507 Chelles cedex - FRANCE

s.bennell@rotisol.com - Tel : +33 1 64 21 80 00

www.rotisol.com